

User Manual

Flap Barrier Turnstile-FBL6000 Pro Series

Applicable Model(s): FBL1000 Pro series, FBL1200 Pro series, FBL2000 Pro series, FBL2200 Pro series, FBL4000 Pro series, FBL4200 Pro series, FBL5000 Pro series, FBL5200 Pro series, FBL6000 Pro series, FBL6200 Pro series

Version: 1.1

Date: October 2019

Contents

1. Product Introduction	1
1.1 Product Appearance and Dimensions	1
1.2 Technical Parameters	2
1.3 Model Number and Access Control.....	2
2. Power-on Test Prior to Installation	3
3. Electric and Civil Installation	4
4. Menu Operation.....	7
5. Wiring Diagram	9
6. Product Maintenance.....	10
6.1 Chassis.....	10
6.2 Movement.....	10
6.3 Power	10

1. Product Introduction

The wing gate is composed of the chassis, core component, wing arms, a PCB (printed circuit board), infrared sensors, a reader, and the access control system.

The system uses standard electric interfaces. It meets fire fighting passage requirements and is equipped with dedicated fire control linkage interfaces. The entire system complies with the same quality standard to ensure reliability, stability, and smoothness of the system during running.

The wing gate is applicable to work attendance, access control, consumption management, and special passage control of enterprises and institutional organizations. It is conducive to the management of ticket check passages in stations, wharves, convention and exhibition centres, and swimming pools.

1.1 Product Appearance and Dimensions

Below is the design and dimensions of FBL6000 Pro:

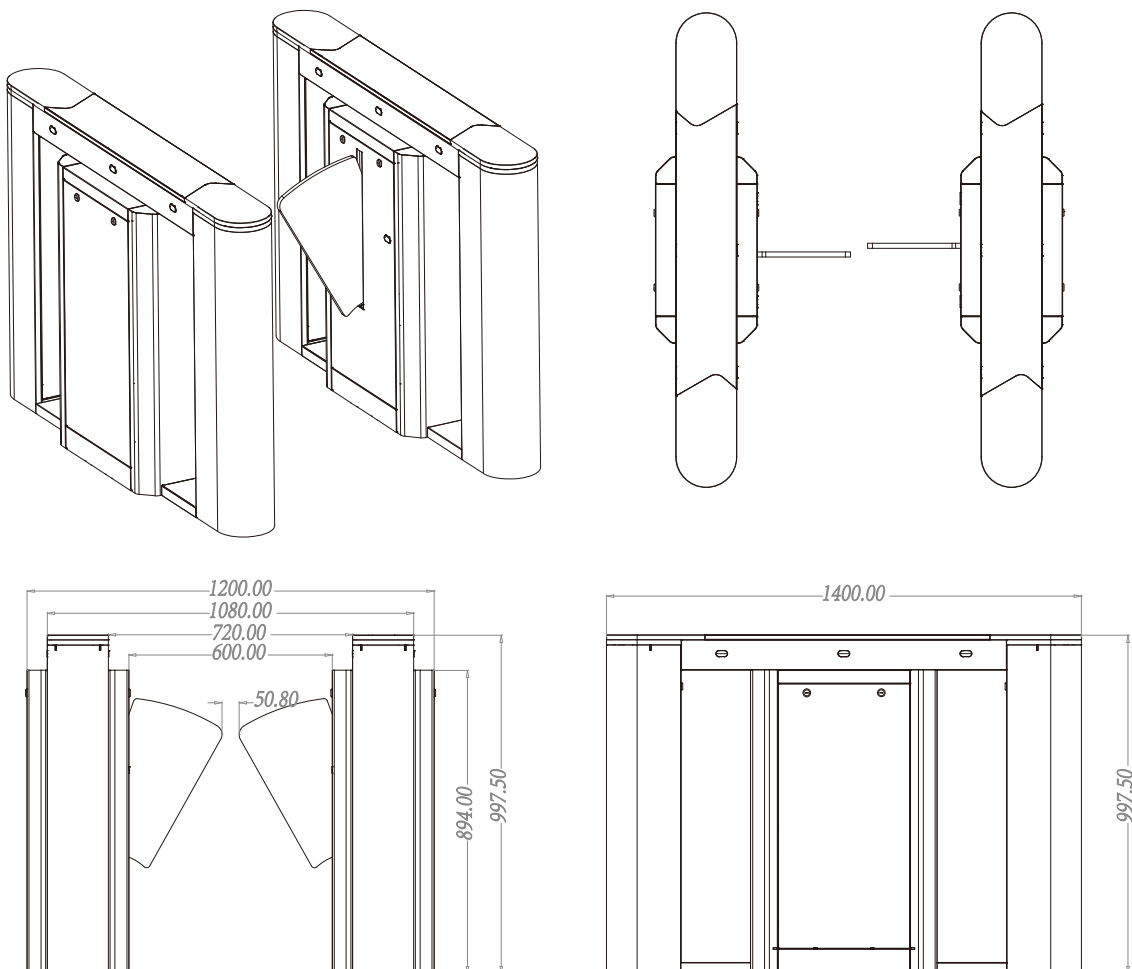

1.2 Technical Parameters

Dimension (mm)	FBL6000 Pro: L = 1400, W = 300, H = 1000		
Lane width	600mm	Input voltage	AC110 ~ 240V; 50 - 60Hz
Input control signal	Switching signal	Output voltage	DC24V
Time of opening/closing	1 second (adjustable)	Relative humidity	5% - 80%
Temperature	-28°C to 60°C	Passage rate	Maximum 30/minute
Infrared sensor	5	Working environment	Indoor

1.3 The model number and access control

Access Model	None	C3-200 and 2*Wiegand reader	inBio 260 and 2* FR1500/ID reader	2*Facedepot 7B device
FBL6000 Pro	√			
FBL6011 Pro		√		
FBL6022 Pro			√	
FBL6033 Pro				√
FBL6200 Pro	√			
FBL6211 Pro		√		
FBL6222 Pro			√	
FBL6233 Pro				√

Figure 1-1

2. Power-on Test Prior to Installation

Test Procedure:

1. Connect a temporary test cable to the device and supply the input power of AC100-240V adaptive to the device (Note that a ground cable must be connected.)
2. Wait 30 seconds till the wing gate completes the self-test procedure.
3. Start the air switch inside the wing gate to check whether the wing gate functions properly and check whether the LED indicators function properly. If they all function properly, start the civil installation. If an exception occurs, contact your sales agent.

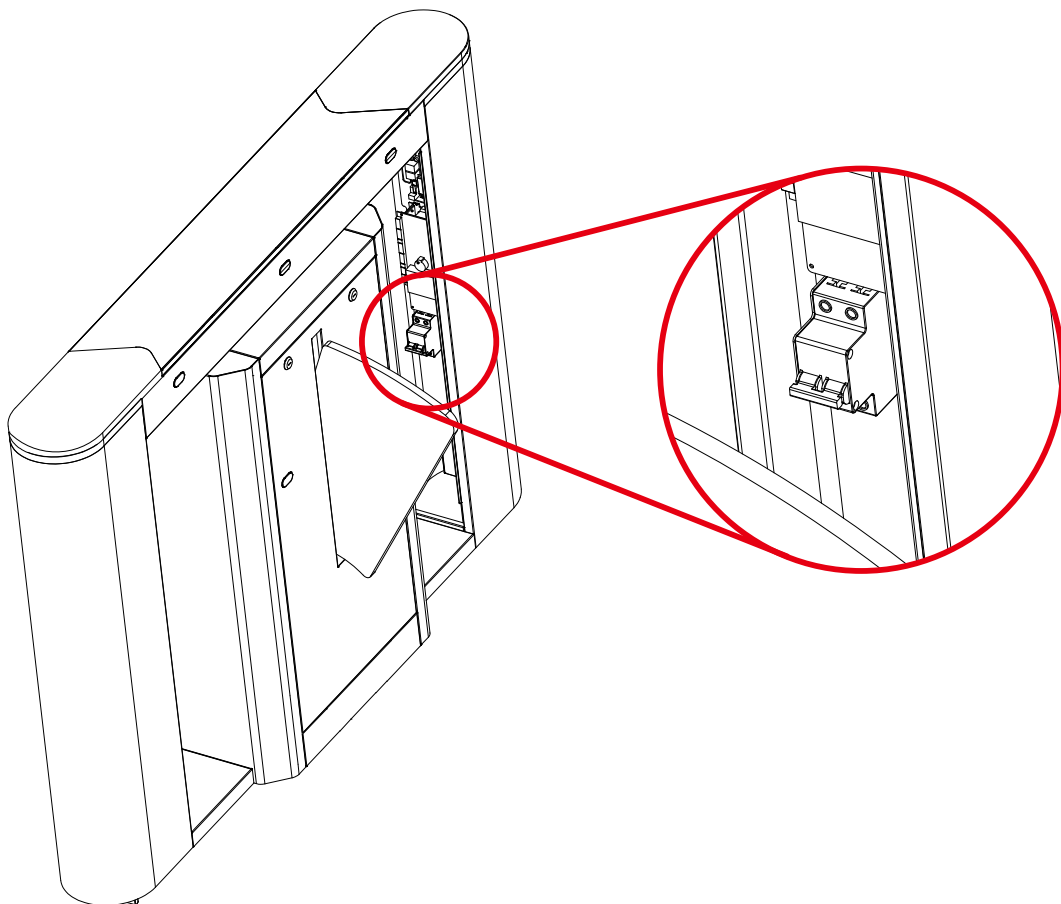

Figure 2-1 Air Switch

3. Electric and Civil Installation

1. Device installation conditions

The location where the device is installed must be a concrete flat surface so that the expansion screws can be fastened firmly. If the planned foundation does not meet this criterion, consult professional building or decoration personnel and create stable conditions for firmly fastening of the wing gate.

2. Determination of the location of device installation

Decide the installation location based on the space needed as illustrated in Figure 3-1A and Figure 3-1B.

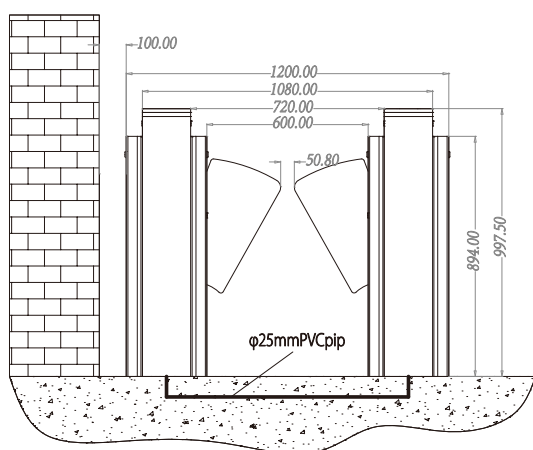

Figure 3-1A Single-Passage Wing Gate

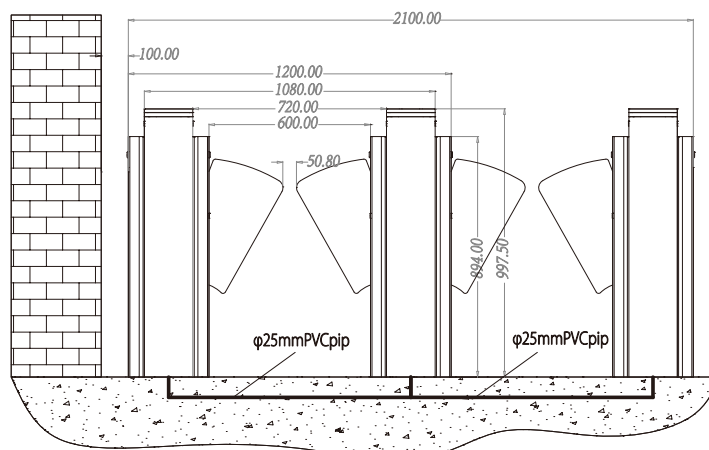

Figure 3-1B Dual-Passage Wing Gate

3. Cable connection

For the location of the hole where the cables come out, please refer to Figure 3-2 below.

4. Device installation

- Turn on the master machine and slave machine, adjust the wing arms to ensure that the wing arms are in the same line and the distance between wings is 50 mm. Turn the wings to the OFF state.
- Test whether the infrared rays transmitted by infrared sensors on both sides align with each other.
- Make marks: Mark the screw hole of the base and chassis base edges on the ground.

d) Drill holes: Get ready a hammer drill and a 14 mm drill bit, vertically drill a hole with the depth of 80 mm in the screw hole centre marks.

Alternatively, drill holes according to installation hole positions, see Figure 3-2 for installation hole positions. The unit of the figures in the drawings is mm.

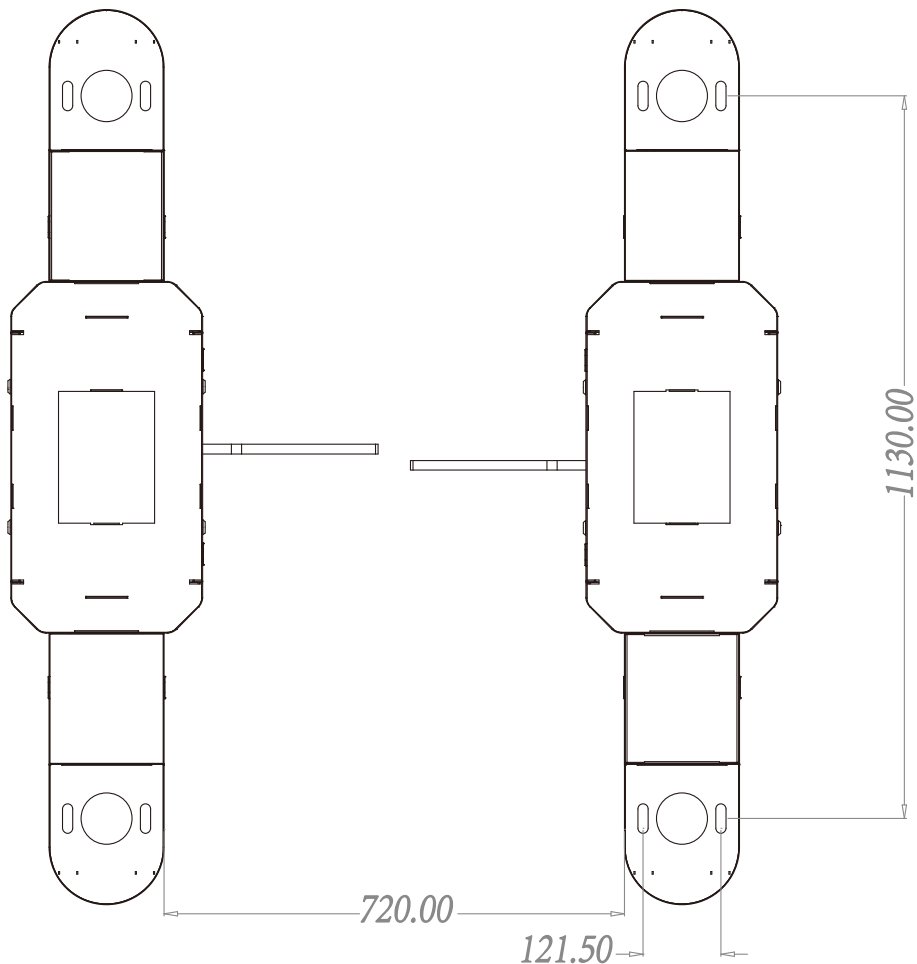

Figure 3-2

e) Apply screw glue to the outer surface and threads of the expansion screws, insert expansion screws, and put the master machine and slave machine in the marked positions. Use a level to check whether the installation ground foundation is level. If not, use a pad for adjustment.

Note: Eight expansion screws must be completely inserted, as shown in Figure 3-3.

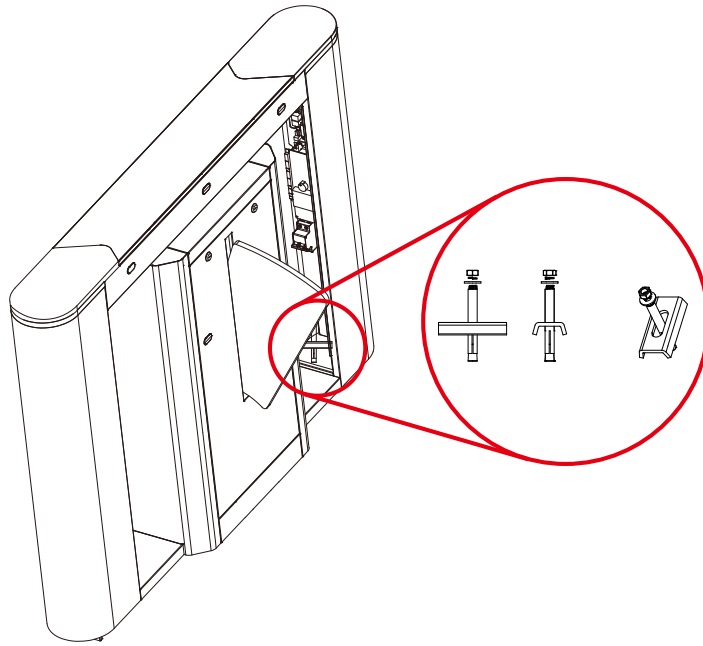

Figure 3-3

5. Card Swiping Warning Lines

It is recommended that a warning line is set to prompt users to swipe cards outside the warning lines, as shown in Figure 3-4.

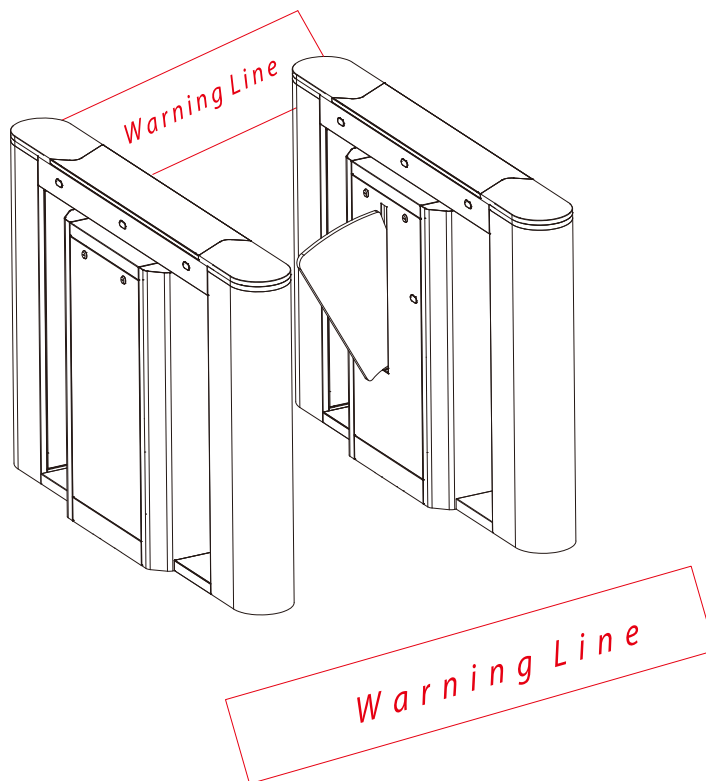

Figure 3-4

4. Menu Operation

- **Menu**

There are four keys on the control panel, including "UP", "DOWN", "ENT", and "ESC". Press "ENT" to modify settings, press "UP" and "DOWN" button to select a function, and press "ESC" to exit.

- **The menu has the following options:**

- 1. Passing mode**

- Two-way swipe (default)

- Left free, Right swipe

- Left swipe, Right free

- Two-way free

- Left prohibit, Right swipe

- Left swipe, Right prohibit

- Left prohibit, Right free

- Left free, Right prohibit

- Two-way prohibit

- 2. Opening speed**

- Low speed

- Medium speed (default)

- High speed

- 3. Closing speed**

- Low speed

- Medium speed (default)

- High speed

- 4. Volume setting**

- Volume: off

- The value ranges from 1 to 16 (default 5).

- 1 is the minimum value; 16 is the maximum value.

- 5. Opening duration**

- After the gate is opened, it will be automatically closed if no one passes through within a certain duration. The default value is 10 seconds. The value ranges from 5 to 60.

- 6. Reset the counter**

- Exit counter

- Entry counter

- All (default)

7. Gate closing delay time

Time: 0~10s (default 0s)

8. Trailing alarm detection

Mode: Close the door and audio alarm

Audio alarm only (default)

Disable the alarm function

9. Swiping mode

Method: Allow card swiping in the channel (default)

Do not allow card swiping in the channel

10. False direction entry

Mode: Close the door and audio alarm

Audio alarm only (default)

Disable the alarm function

11. Set fire signal

Enable (default)

Disable

12. Exchange voice of door opening

Yes

No (default)

13. Speed compensation of master machine

Compensation value: 000

1~20 (default: 000)

14. Speed compensation of slave machine

Compensation value: 000

1~20 (default: 000)

15. Gate closing mode

Out of the anti-pinch area, close the gate. (default)

Out of the channel, close the gate.

16. Memory opening

Whether to open: No (default)

Yes

17. System working mode

Mode: Working mode (default)

Test mode

Restore to factory

18. Version number

Version: V7.0.3

5. Wiring Diagram

Below is the wiring diagram:

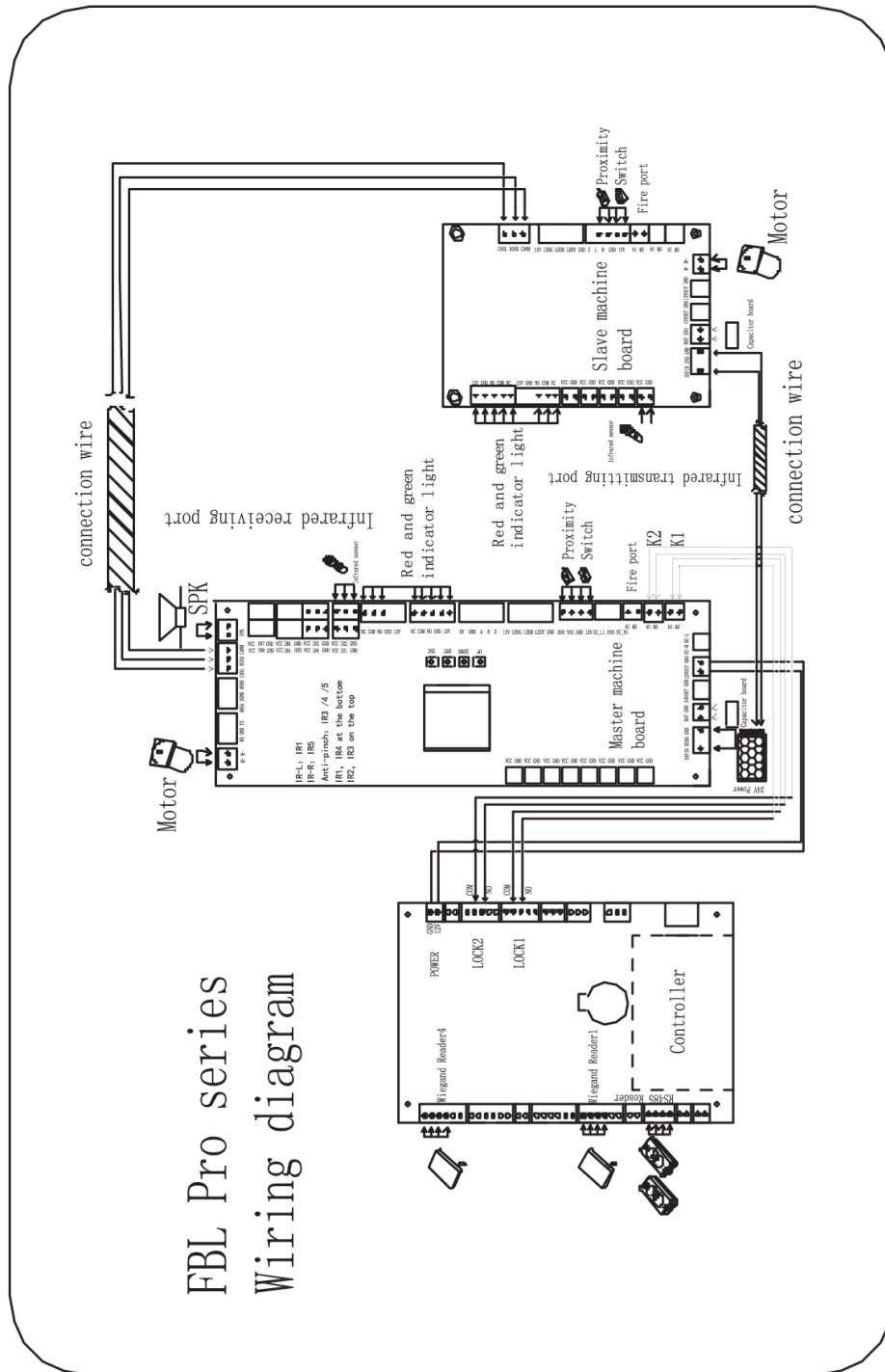

Figure 5-1

6. Product Maintenance

6.1 Chassis

The chassis is made of SAE 304 stainless steel. When the device has been used for a long period, there may be rust or stain on the surface of the chassis. Remember to regularly sand the surface along the grain softly and carefully, then coat the surface with anti-rust oil. Avoid covering the infrared sensors.

6.2 Movement

Cut off the power supply before maintenance. Then, open the door, wipe off the dust on the surface, and lubricate the transmission mechanism. Check and tighten other connection parts.

6.3 Power

Cut off the power supply before maintenance. Check the plug connection; if anything is loose, fix it. Do not randomly change any connection positioning. Check the external power insulation regularly. Do periodic check for any kind of leakage. Check if the technical parameters of each interface are normal. Check the service life of the electronic components.

Caution: The above-mentioned maintenance method of the swing gates, especially the movement and the electric control maintenance, must be carried out by professional personnel. Always remember to cut off the power supply before maintenance and repair.

www.zkteco.com

