

---

# KR613 User manual

## 1 Overview

KR613 dual frequency Contactless card reader, is based on ISO / EM4001 international standard protocol development of non-contact smart card serial number reader. It uses the company's own design of high-performance RF card reader circuit design; with a high degree of integration, anti-interference ability, small size, stable performance, cost-effective features. Can provide standard Wiegand communication interface for access control, time and attendance, fees, security, Patrol and other radio frequency identification applications.

## 2. Features

- The card reader is equipped with a card-reading antenna that works at 125khz/13.56MHz, ID Card, Mifare/Desfire Card
- The effective distance ranges from 0 to 5cm, depending on the working environment and card type.
- The data receiving time is less than 80ms within the effective distance.
- The card reader adopts the single +12 VDC power supply, and the operating current is less than 100mA.
- The data is output in the standard Wiegand34 bits format by default.
- The card reader is produced using the fully closed rubber injecting operation to achieve the waterproof and moisture-proof effects.
- The effective distance is associated with the voltage of the power supply, used IC cards, and operating environment.

## 3. Wire Function Description

Red wire: VCC; +12V

Black wire: GND

Green wire: Wiegand D0

White wire: Wiegand D1

Grey wire: Green LED

Purple wire: Beeper

## 4. Specifications

### 4.1 Limit Parameters

project	Value	unit
+12V, Vcc	12.5	V
Data0, IO/Clock, ICK	±20	mA
Data1, I1/Data, IC	±20	mA
Hold, IH/Card Present, ICP	±25	mA
antenna ,IAN	±43	mA
Operating temperature ,TOPR	-10~70	°C
Storage temperature ,TSTR	-55~+125	°C

### 4.2 Electrical, mechanical properties (No special instructions TA=25°, Vcc=12V)

project	Min	typical	Max	unit
+12V, Vcc	7	12	14	V
Working current, Ic		70	110	mA
working frequency, FRES	13.52	13.56	13.58	MHz
effective distance, D *	20	30	40	mm
Decoding time, TDEC	65	100		ms
Data0, Data1, Hold/ata, Clock, Card, Present, Output high potential, VoH	2.4 (IoH=80uA), 0.75Vcc (IoH=30uA) 0.9Vcc (IoH=12uA)			V
Data0, Data1, Hold/ata, Clock, Card, Present Output low potential, VoL	0.5 ( IoL=20mA, Vcc=5V, IoL=20mA, Vcc=3.3V)			V

---

## 5. Connections

### 5.1 Wiegand Connections

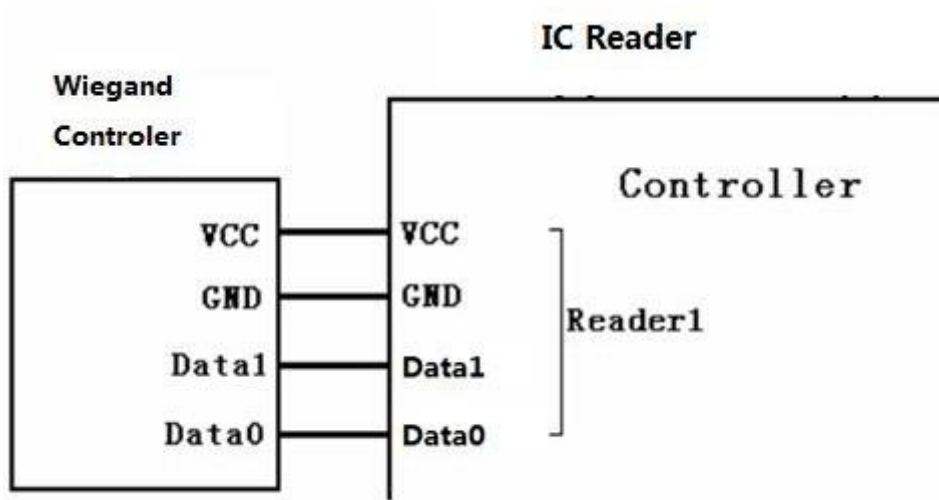

---

## **6 Precautions**

1. The operating frequency of the card reader is 125 kHz/13.56MHz. Therefore, interference frequency ranging

---

from 13MHz to 15MHz cannot exist on the site where the card reader is installed.

2. To prevent emission magnetic fields of card readers from affecting each other, the installation distance between every two card readers must be greater than 10 cm.

---

"Hereby, ZKTECO CO., LTD. declares that this Card Reader is in compliance with the essential requirements and other relevant provisions of Directive 2014/53/EU.

This device complies with Part 15 of the FCC Rules.

Operation is subject to the following two conditions:

- (1) This device may not cause harmful interference, and
- (2) This device must accept any interference received, including interference that may cause undesired operation.

**Warning:** Changes or modifications to this unit not expressly approved by the party responsible for compliance could void the user's authority to operate the equipment.

**Note:** This equipment has been tested and found to comply with the limits for a Class B digital device, pursuant to Part 15 of the FCC Rules. These limits are designed to provide reasonable protection against harmful interference in a residential installation. This equipment generates, uses and can radiate radio frequency energy and, if not installed and used in accordance with the instructions, may cause harmful interference to radio communications. However, there is no guarantee that interference will not occur in a particular installation. If this equipment does cause harmful interference to radio or television reception, which can be determined by turning the equipment off and on, the user is encouraged to try to correct the interference by one or more of the following measures:

- Reorient or relocate the receiving antenna.
- Increase the separation between the equipment and receiver.
- Connect the equipment into an outlet on a circuit different from that to which the receiver is connected.
- Consult the dealer or an experienced radio/TV technician for help.

"This equipment complies with FCC RF radiation exposure limits set forth for an uncontrolled environment.

---

This equipment should be installed and operated with a minimum distance of 20 centimeters between the radiator and your body."

ZKTECO EUROPE SL

Address: CTRA. FUENCARRAL 44. EDIFICIO 1.

ALCOBENDAS, 28108, MADRID